

MAXIM

MAX3277 Evaluation Kit

General Description

The MAX3277 evaluation kit (EV kit) allows complete evaluation of the MAX3277 transimpedance amplifier. The EV kit includes a circuit that emulates the high-speed, zero-to-peak current input signal that would be produced by a photodiode. The kit also includes a calibration circuit that allows accurate bandwidth and jitter measurements.

The MAX3277 EV kit is fully assembled and tested.

Component List

DESIGNATION	QTY	DESCRIPTION
C1	1	0.01 μ F \pm 10% ceramic capacitor (0402)
C2	1	10 μ F \pm 10% tantalum capacitor
C5–C9	5	0.1 μ F \pm 10% ceramic capacitors (0402)
C11, C12	2	1000pF \pm 10% ceramic capacitors (0402)
J1–J5	5	SMA connectors, edge mount (round contact)
J8	1	1 \times 2-pin header (0.1in center)
L1	1	56nH inductor Coilcraft 0805CS-560XKBC
R1, R6	2	49.9 Ω \pm 1% resistors (0402)
R2, R5	2	1k Ω \pm 1% resistors (0402)
R3, R4, R7, R8	4	499 Ω \pm 1% resistors (0402)
TP1, TP2, J6, J7	4	Test points
U1	1	MAX3277U/D die
None	1	MAX3277 EV kit circuit board
None	1	MAX3275/MAX3277 data sheet

Features

- ◆ Fully Assembled and Tested
- ◆ Includes Photodiode Emulation Circuit
- ◆ Includes Calibration Circuit for Accurate Bandwidth and Jitter Measurements

Ordering Information

PART	TEMP RANGE	IC PACKAGE
MAX3277EVKIT	0°C to +85°C	MAX3277UID Chip On-Board

Component Suppliers

SUPPLIER	PHONE	FAX
AVX	843-444-2863	843-626-3123
Coilcraft	408-224-8566	408-224-6304
Murata	415-964-6321	415-964-8165
Ventel	800-950-8365	512-794-0087

Note: Please indicate that you are using the MAX3277 when contacting these component suppliers.

Evaluates: MAX3277

MAX3277 Evaluation Kit

Quick Start

- 1) Connect a signal source to IN (J3). Set the signal amplitude to 50mV_{P-P} (corresponding to 50μA_{P-P} current into the TIA). This may require attenuation between the source and the MAX3277 EV kit. The signal should have a data rate of up to 2.125Gbps.
- 2) Apply 30μA to TP1 using a constant current source to emulate the DC component of the input signal.
- 3) Connect OUT+ (J1) and OUT- (J2) to the 50Ω inputs of a high-speed oscilloscope.
- 4) Remove the shunt from jumper J8 to enable DC cancellation loop.
- 5) Connect a 3.3V supply to the VCC terminal (J6) and ground to the GND terminal (J7).
- 6) The differential signal at the oscilloscope should be approximately 165mV_{P-P}.

Detailed Description

The MAX3277 EV kit allows characterization of the MAX3277 TIA without a photodiode. The MAX3277 is designed to accept a DC-coupled input from a high-speed photodiode. Diode currents can have 10μA_{P-P} to 2mA_{P-P} AC current with a DC component from 5μA to 1mA. The high-speed current source of the photodiode is emulated on the EV kit using separate AC and DC paths. The AC signal is supplied from a standard 50Ω lab source that delivers power to an on-board termination resistor. A current is then generated from the voltage signal by a resistor with low stray capacitance. The effect of the DC photodiode current can be emulated by a current source at TP1. An isolation resistor prevents the DC source from loading the AC path.

The values of the series-resistive elements, R4 and R7, have been selected carefully so that the bandwidth of the transimpedance amplifier is not altered. Surface-

mount resistors have parasitic capacitance that reduces their impedance at frequencies above 1GHz. Changes to R4 and R7 must be evaluated using the calibration network.

Photodiode Emulation

Use the following procedure to emulate the high-speed current signal generated by a photodiode:

- 1) Select the desired optical power (P_{AVE} in dBm) and extinction ratio (r_e).
- 2) Calculate the average current (I_{AVE} in Amps). Set the DC current at TP1 to I_{AVE} :

$$I_{AVE} = \left(\frac{10^{(P_{AVE}/10)}}{1000} \right) \rho$$

(ρ = photodiode responsivity in A/W)

- 3) Calculate the AC signal current (I_{AC}) and adjust the signal generator to obtain it:

$$I_{AC} = 2I_{AVE} \left(\frac{r_e - 1}{r_e + 1} \right)$$

For example: To emulate a photodiode with an average power of -16dBm and an extinction ratio of 10:

- 1) -16dBm optical power will produce 25μA of average input current (assume photodiode responsivity of 1A/W). Set the DC current input to 25μA at TP1.
- 2) The AC signal current is $2I_{AVE} (r_e - 1)/(r_e + 1) = 41\mu A$. To generate this current through the 1000Ω input resistors, set the signal source to produce an output level of 41μA (1000Ω) = 41mV_{P-P}.

MAX3277 Evaluation Kit

Evaluates: MAX3277

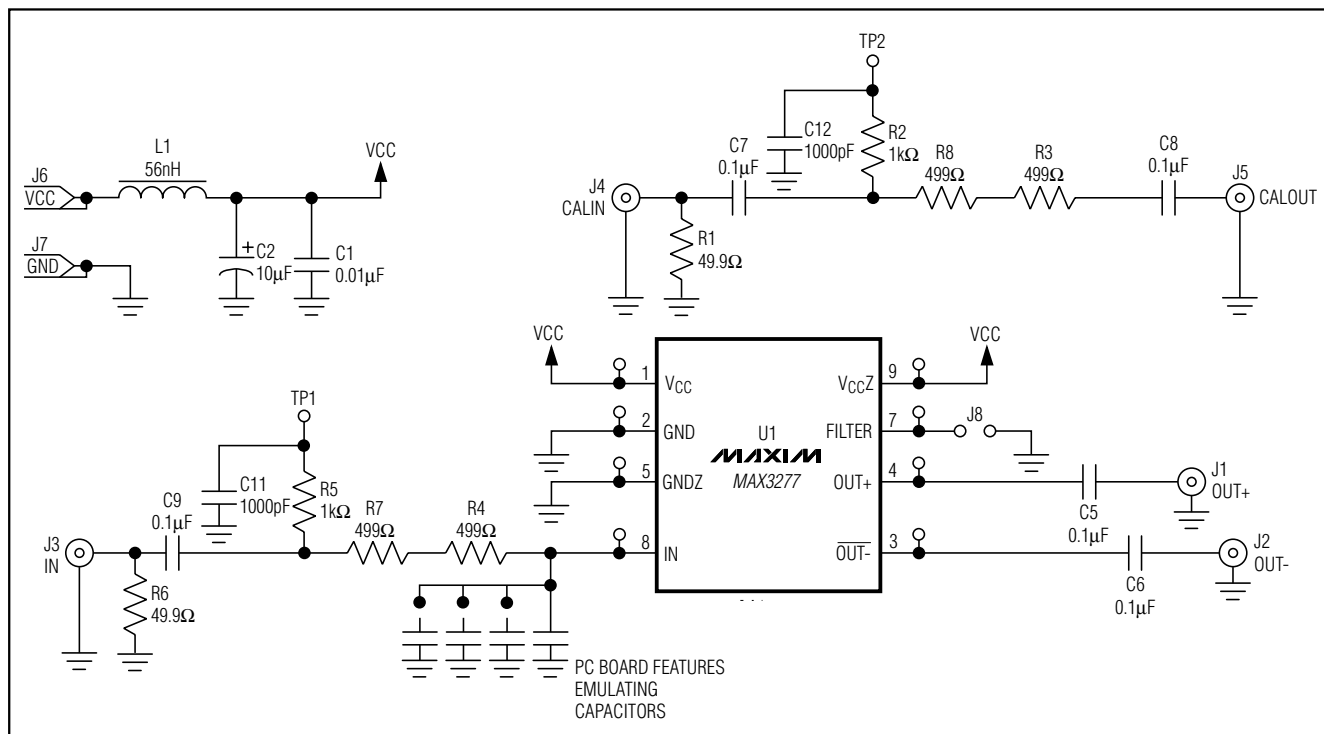

Figure 1. MAX3277 EV Kit Schematic

MAX3277 Evaluation Kit

Evaluates: MAX3277

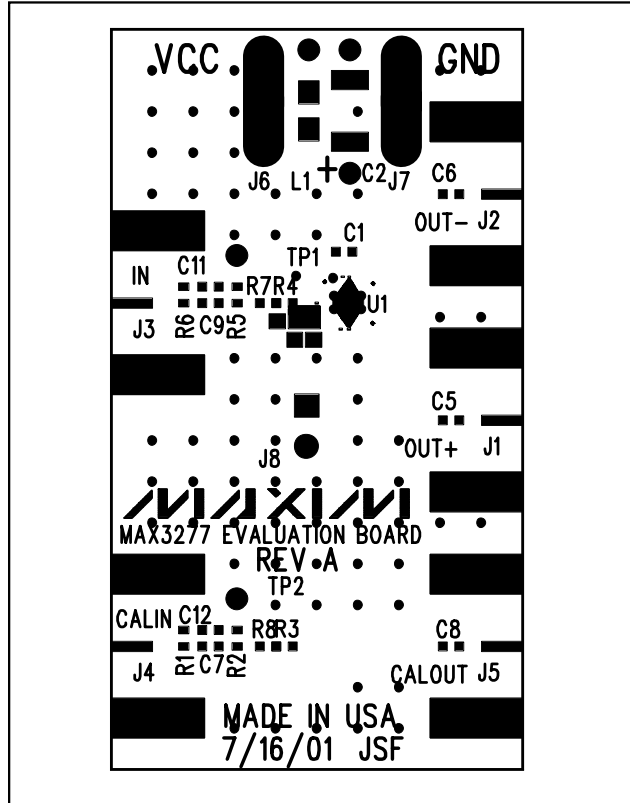

Figure 2. MAX3277 EV Kit Component Placement Guide—Component Side

MAX3277 Evaluation Kit

Evaluates: MAX3277

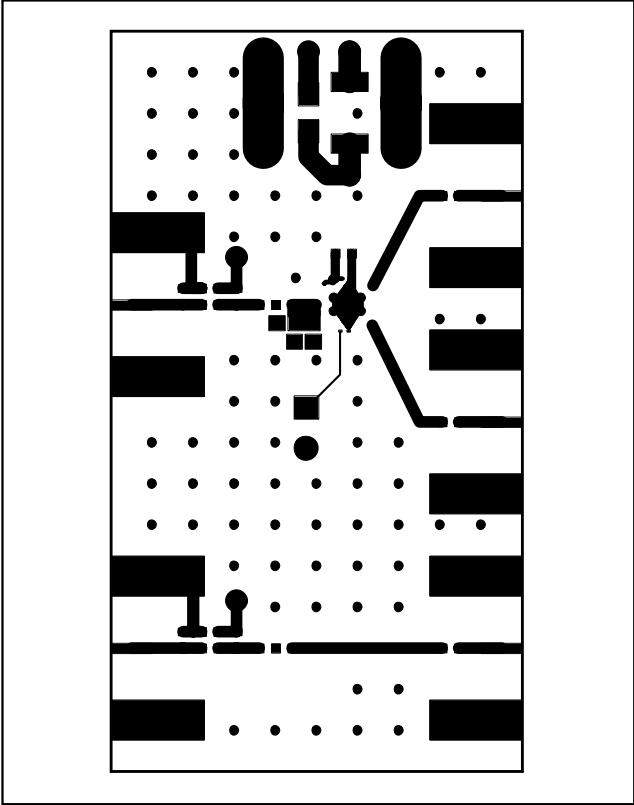

Figure 3. MAX3277 EV Kit PC Board Layout—Component Side

MAX3277 Evaluation Kit

Evaluates: MAX3277

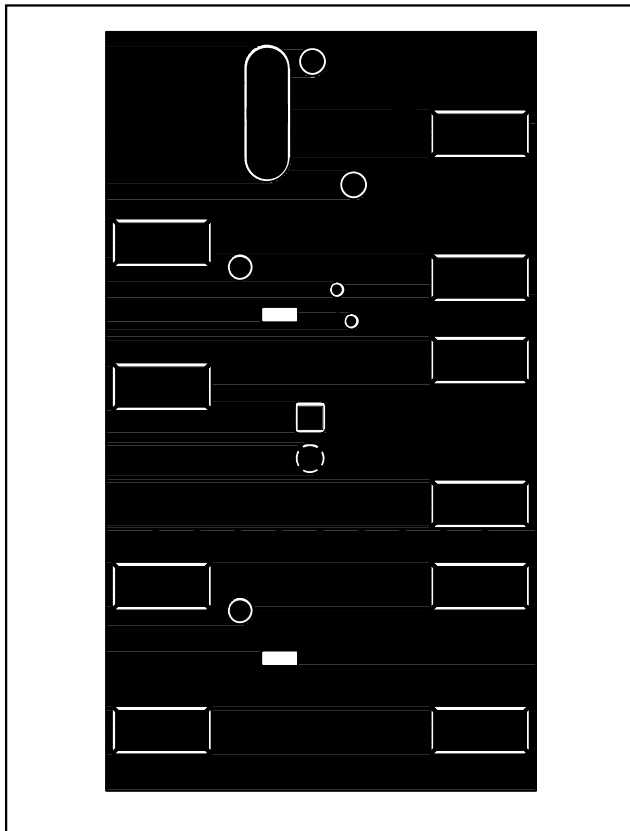

Figure 4. MAX3277 EV Kit PC Board Layout—Solder Side

MAX3277 Evaluation Kit

Evaluates: MAX3277

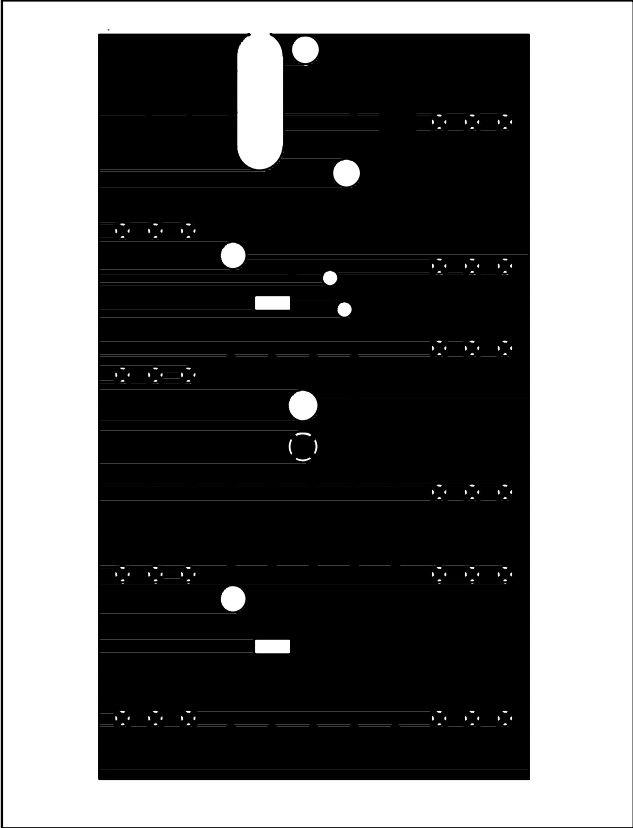

Figure 5. MAX3277 EV Kit PC Board Layout—Ground Plane

MAX3277 Evaluation Kit

Evaluates: MAX3277

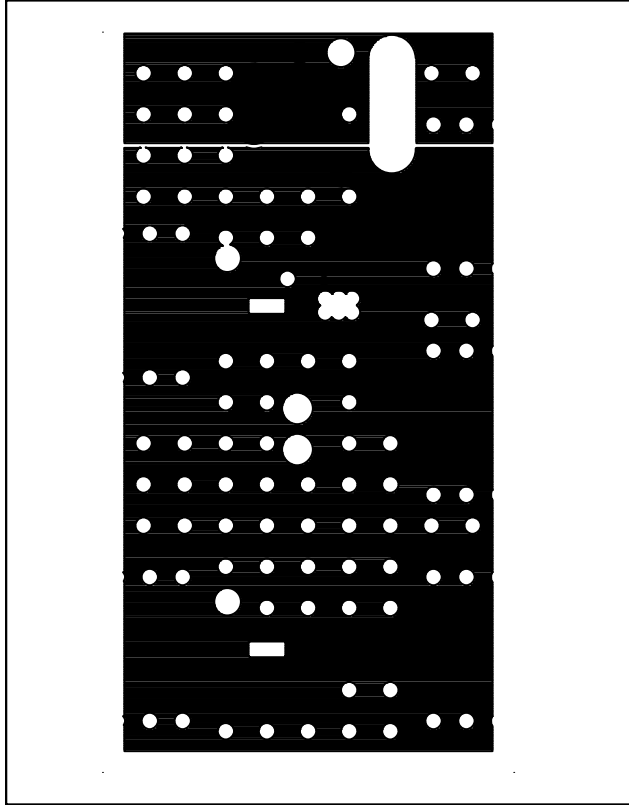

Figure 6. MAX3277 EV Kit PC Board Layout—Power Plane

Maxim cannot assume responsibility for use of any circuitry other than circuitry entirely embodied in a Maxim product. No circuit patent licenses are implied. Maxim reserves the right to change the circuitry and specifications without notice at any time.

8 _____ **Maxim Integrated Products, 120 San Gabriel Drive, Sunnyvale, CA 94086 408-737-7600**